

Cage Code: 704Q7

RevNo	Revision note	Date	Signature	Checked
-------	---------------	------	-----------	---------

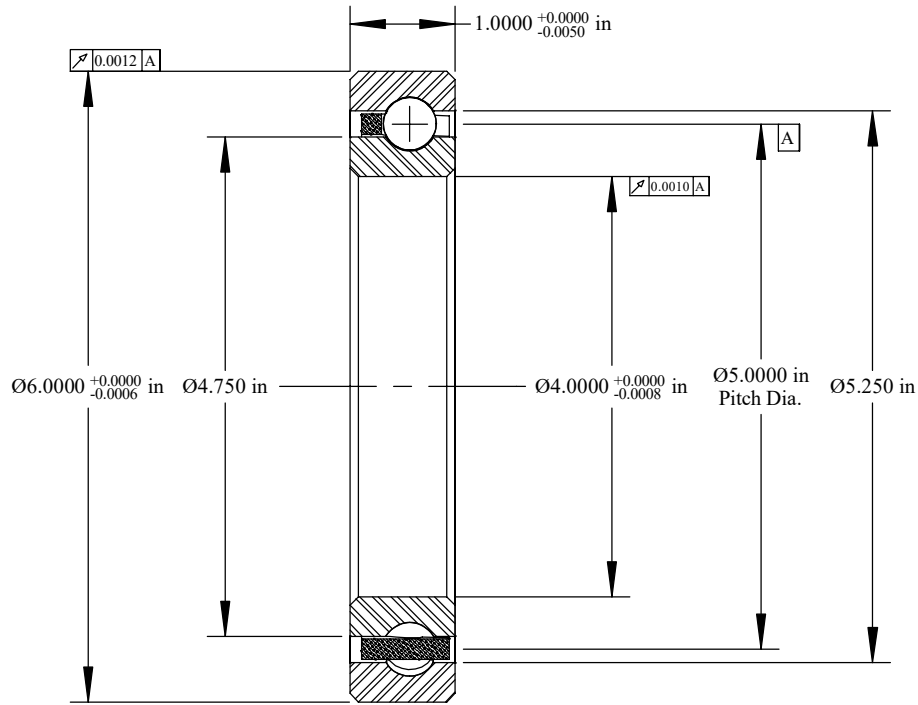

Scale: 1:1 Will Clear 0.080  
Max. Fillet Radius  
4 Exterior Corners

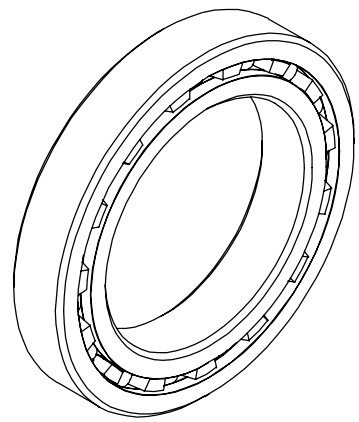

	OUTER	INNER	SEPARATOR	BALL
MATERIAL	52100	52100	BRASS	52100
HARDNESS	Rc 59-62	Rc 59-62		
RACE RUN-OUT	OUTER	INNER		
ABEC RATING	PRELOAD		ROLLING ELEMENT QUANTITY	
1	N/A		15	1/2
RADIAL LOAD	THRUST LOAD		MOMENT LOAD	
DYNAMIC: 6115 Lbs. STATIC: 8210 Lbs.	N/A		N/A	
RADIAL PLAY	CONTACT ANGLE		LIMITING SPEED	
0.0016 0.0028	N/A		5,250 RPM	
LUBRICATION	SEAL		BEARING WEIGHT	
LIGHT OIL PRESERVATIVE	N/A		3.60 Lbs.	

UNLESS OTHERWISE SPECIFIED ALL DIMENSIONS IN INCHES

Designed by ML	Checked by ML	This drawing and the information contained herein are proprietary and the property of Rfbearing Corporation.
RG040CP0		Radial Thin Section Ball Bearing
File name RG040CP0	Date September 8, 2017	REVISION A Sheet 1 of 1

**SSB**  
thin section bearings

Corporate Headquarters  
18181 Praire Drive  
Covington, GA 30014  
(800) 431-1980  
www.rfbearing.com